

**AGENDA OF THE COMMON COUNCIL
City of Angola, Indiana
210 N. Public Square**

Monday, March 3, 2025 – 7:00 p.m.

CALL TO ORDER BY MAYOR MARTIN

1. Council Member roll call by Clerk-Treasurer Herbert.

Coffey _____ Olson _____ Sharkey _____ Dowe _____ McDermid _____

2. Request approval of the February 10, 17, and 24 minutes. (attachment)
 - Minutes of the January 6 Board of Public Works and Safety meeting presented for Council information. (attachment)

UNFINISHED BUSINESS

1. Ordinance No. 1771-2025. ADDITIONAL APPROPRIATION ORDINANCE FOR THE CITY OF ANGOLA, INDIANA LOCAL ROAD AND BRIDGE MATCHING GRANT FUND. (second reading) (attachment)
2. Consideration and action on bids for the Pokagon Infrastructure Improvement Project Divisions 1-4 opened at the February 24 special meeting.
3. Other unfinished business.

NEW BUSINESS

1. Presentation by Jason Meyer Director of Business Partnerships and Strategic Initiatives of Easterseals Northeast Indiana.
2. Request approval of Change Order No 2 for the Angola WWTP Biosolids Improvement Project for a decrease in the amount of \$5,576.98. (attachment)
3. Reports:
 - Clerk-Treasurer
 - Department heads
4. Request approval of the Allowance of Accounts Payable Vouchers 72983 through 73227 totaling \$754,555.47.
5. Other new business.

NEXT MEETING

The next Common Council meeting is Monday March 17, 2025.

ADJOURNMENT

This in-person meeting will be livestreamed on www.youtube.com/@AngolaIN

Individuals with disabilities who require accommodations for participation in meetings must request accommodations at least three business days ahead of scheduled meeting. Contact the Clerk-Treasurer, 210 North Public Square, Angola, IN 46703, (260) 665-2514 extension 7353, clerktreasurer@angolain.org as soon as possible but no later than three business days before the scheduled event.



February 10, 2025

The special meeting of the Common Council of the City of Angola, Indiana was called to order at 7:00 p.m. at City Hall, 210 North Public Square with Mayor David B. Martin presiding. Council Members Randy Coffey, David A. Olson, Jennifer L. Sharkey, Charles P. Dowe, and Jerold D. McDermid answered roll. No Council Member was absent. Clerk-Treasurer Ryan P. Herbert recorded the minutes.

Among those present were City Attorney Kim Shoup, City Engineer Amanda Cope, Police Chief Ken Whitmire, Street Commissioner Chad Ritter, and Assistant Street Commissioner Scott Stevens

Also among those present were Sam Witney, Annalise O'Daniel, and Logan Hooley

NEW BUSINESS

Bids for the Community Crossing Project #2024-02 were opened by City Engineer Cope and read aloud as follows:

API Construction	\$1,811,300.00
Brooks Construction	\$1,894,929.00

Discussion followed. Council Member Olson moved to award the lowest, most responsive, and responsible bidder.. Council Member Sharkey seconded the motion. The motion carried 5-0.

ADJOURNMENT

There being no further business, the meeting was considered adjourned at 7:06 p.m.

David B. Martin, Mayor
Presiding Officer

Attest:

Ryan P. Herbert, Clerk-Treasurer

February 17, 2025

The regular meeting of the Common Council of the City of Angola, Indiana was called to order at 7:00 p.m. at City Hall, 210 North Public Square with Mayor David B. Martin presiding. Council Members Randy Coffey, David A. Olson, Jennifer L. Sharkey, Charles P. Dowe, and Jerold D. McDermid answered roll. No Council Member was absent. Clerk-Treasurer Ryan P. Herbert recorded the minutes.

Among those present were City Attorney Kim Shoup, City Engineer Amanda Cope, Economic Development and Planning Director Retha Hicks, Police Chief Ken Whitmire, Fire Chief Bill Harter, Street Commissioner Chad Ritter, Wastewater Superintendent Jeff Gaff, and Park Superintendent Matt Hanna and Human Resources Director Sue Essman.

Also among those present were John Cannon, Chad Salzbrenner, and Chris Emerick.

APPROVAL OF THE MINUTES

Council Member Olson moved to approve the February 3, 2025 minutes. Council Member Coffey seconded the motion. The motion carried 5-0.

UNFINISHED BUSINESS

Ordinance No. AN ORDINANCE AMENDING THE ZONING MAP OF THE CITY OF ANGOLA, INDIANA. (1850 N SR 827), was read by title and presented to Council for third and final reading. Council Member Olson having reviewed the findings of the Plan Commission and taking into account the comprehensive plan, current conditions and character of the structures and uses in each district, the most desirable use of the land in its current and proposed zones, conservation of property value throughout the city, and responsible growth and development moved to adopt the proposed zoning change. Council Member Sharkey seconded the motion. The motion carried 5-0.

Ordinance No.1771-2025, AN ORDINANCE OF THE CITY OF ANGOLA AUTHORIZING THE ISSUANCE OF WATERWORKS REVENUE BONDS FOR THE PURPOSE OF PROVIDING FUNDS TO PAY THE COST OF CERTAIN ADDITIONS, EXTENSIONS AND IMPROVEMENTS TO THE MUNICIPAL WATERWORKS OF SAID CITY, THE ISSUANCE OF REVENUE BONDS TO PROVIDE FOR THE COST THEREOF, THE COLLECTION, SEGREGATION AND DISTRIBUTION OF THE REVENUES OF SAID WORKS, PROVIDING FOR THE SAFEGUARDING OF THE INTERESTS OF THE OWNERS OF SAID BONDS, OTHER MATTERS CONNECTED THEREWITH, INCLUDING THE ISSUANCE OF NOTES IN ANTICIPATION OF BONDS, AND REPEALING ORDINANCES INCONSISTENT HERewith, was read by title and presented to Council on second reading. Council Member Olson moved to approve. Council Member McDermid seconded the motion. The motion carried 5-0.

Ordinance No. 1772-2025. AN ORDINANCE OF THE CITY OF ANGOLA AUTHORIZING THE ISSUANCE OF SEWAGE WORKS REVENUE BONDS FOR

THE PURPOSE OF PROVIDING FUNDS TO PAY THE COST OF CERTAIN ADDITIONS, EXTENSIONS AND IMPROVEMENTS TO THE SEWAGE WORKS OF SAID CITY, THE ISSUANCE OF REVENUE BONDS TO PROVIDE FOR THE COST THEREOF, THE COLLECTION, SEGREGATION AND DISTRIBUTION OF THE REVENUES OF SAID WORKS, PROVIDING FOR THE SAFEGUARDING OF THE INTERESTS OF THE OWNERS OF SAID BONDS, OTHER MATTERS CONNECTED THEREWITH, INCLUDING THE ISSUANCE OF NOTES IN ANTICIPATION OF BONDS, AND REPEALING ORDINANCES INCONSISTENT HEREWITH. was read by title and presented to Council on second reading. Council Member Olson moved to approve. Council Member McDermid seconded the motion. The motion carried 5-0.

NEW BUSINESS

Mayor Martin presented the State of the City.

Ordinance No. 1773-2025, ADDITIONAL APPROPRIATION ORDINANCE FOR THE CITY OF ANGOLA, INDIANA LOCAL ROAD AND BRIDGE MATCHING GRANT FUND, was read by title and presented to Council for first reading. Council Member McDermid moved to approve. Council Member Dowe seconded the motion. Discussion followed. The motion to approve carried 5-0.

Resolution No. 2025-888, A RESOLUTION OF THE COMMON COUNCIL OF THE CITY OF ANGOLA, INDIANA, DETERMINING THAT THERE EXISTS A UNIQUE OPPORTUNITY TO OBTAIN A 2023 SILVERADO TRUCK FOR USE BY THE FIRE DEPARTMENT AT A SUBSTANTIAL SAVINGS TO THE CITY, was read by title and presented to Council for approval. Council Member Olson moved to approve. Council Member Dowe seconded the motion. Discussion followed. The motion to approve carried 5-0.

John Cannon, Deputy Director of External Affairs for the Office of Indiana Attorney General Todd Rokita, provided a presentation to the Council. Cannon discussed some of the accomplishments of the Attorney General Office and services they provided including managing unclaimed property. He also provided information on how citizens can locate and claim that property.

Council Member Coffey moved to approve the LPA- Consulting Contract with Fleis & VandenBrink Engineering for Preliminary Engineering Services for Citywide Sign Replacement Project in the amount not to exceed \$130,000.00. Council Member McDermid seconded the motion. The motion carried 5-0.

Clerk-Treasurer's Depository Statement and Cash Reconciliation for the month ending January 2025 was presented for Council information.

DEPARTMENT HEAD REPORTS

Economic Development and Planning Director Retha Hicks reported that the new City Planner Grace Essman had started work today.

Wastewater Superintendent Gaff reported that the plant has completed the switch to ferric sulphate for treating wastewater. This should help with the ongoing issues with chloride release from the plant.

APPROVAL OF ACCOUNTS PAYABLE VOUCHERS

Council Member McDermid moved to approve the Allowance of Accounts Payable Vouchers 72777 through 72982 totaling \$1,005,058.74 which includes interfund transfers of \$38,334.89. Council Member Sharkey seconded the motion. The motion carried 5-0.

ADJOURNMENT

There being no further business, the meeting was considered adjourned at 7:50 p.m.

David B. Martin, Mayor
Presiding Officer

Attest:

Ryan P. Herbert, Clerk-Treasurer

February 24, 2025

The special meeting of the Common Council of the City of Angola, Indiana was called to order at 7:00 p.m. at City Hall, 210 North Public Square with Mayor David B. Martin presiding. Council Members Randy Coffey, David A. Olson, Jennifer L. Sharkey, Charles P. Dowe, and Jerold D. McDermid answered roll. No Council Member was absent. Clerk-Treasurer Ryan P. Herbert recorded the minutes.

Among those present were City Attorney Kim Shoup, City Engineer Amanda Cope, Water Superintendent Tom Selman, Wastewater Superintendent Jeff Gaff, and Police Patrol Officer Allie Curdes.

Also among those present were County Commissioners Rick Shipe and Wil Howard, Lori Young, Jessie Lestinsky, Nathan Brune, Paul Spitzley, and Jon Howell.

NEW BUSINESS

Bids for the Pokagon Infrastructure Improvement Projects Divisions 1-4 were opened by City Engineer Cope and read aloud as follows:

	Division 1	
Brackney, Inc.		\$12,069,744.00
	Division 2	
Brackney, Inc.		\$12,935,500.00
	Division 3	
Otteweller Contracting, LLC		\$1,069,000.00
Parrish Excavating, Inc.		\$629,558.00
	Division 4	
LC United Painting		\$848,000.00
Seven Brothers Painting Inc.		\$965,440.00
MW Cole Construction		\$869,100.00
O&J Coatings		\$849,000.00
Classic Protective Coatings Inc.		\$985,863.00
L&T Painting Inc.		\$768,400.00
D & 6 sons Painting Inc.		\$882,200.00
Viking Painting LLC		\$1,138,800.00
D&M Painting Corp.		\$973,430.00
Clear Creek Coatings Ltd.		\$753,400.00

Discussion followed. Council Member Olson moved to take the bids under advisement. Council Member Sharkey seconded the motion. The motion carried 5-0.

ADJOURNMENT

There being no further business, the meeting was considered adjourned at 7:16 p.m.

David B. Martin, Mayor
Presiding Officer

Attest:

Ryan P. Herbert, Clerk-Treasurer

DRAFT

JANUARY 6, 2025

The regular meeting of the Board of Public Works and Safety of the City of Angola, Indiana was called to order by Chair David B. Martin at 6:30 p.m. City Hall, 210 N Public Square. Members David B. Martin, David A. Olson, and Jerold D. McDermid answered roll call. No member was absent. Clerk-Treasurer Ryan P. Herbert recorded the minutes.

Among those present were City Attorney Kim Shoup, City Engineer Amanda Cope, Economic Development and Planning Director Retha Hicks, Police Chief Ken Whitmire, Fire Chief Bill Harter, Street Commissioner Chad Ritter, Water Superintendent Tom Selman, Wastewater Superintendent Jeff Gaff, Human Resources Director Sue Essman, Engineering Assistant Nick Gerber and Deputy Clerk Stephanie Dean.

APPROVAL OF MINUTES

Member McDermid moved to approve the December 16, 2024 minutes. Member Olson seconded the motion. The motion carried 3-0.

ORDER OF BUSINESS

Discussion was regarding utility connection fees in conjunction with the Pokagon Utility Extension Project. Consensus was reached that the board would like to pursue waving fees for new connections along the to both systems along the path and asked City Engineer Cope to investigate specifics and put together a program to bring back for approval. No formal action was taken at this time.

DEPARTMENT HEAD REPORTS

Fire Chief Harter reported that he was looking into revisions to department SOP's and may be bringing them to the board for approval in the future.

City Engineer Cope reported that a Stormwater BMPs Maintenance Agreement had been accepted for Vestil Plant 3 located at 351 Pokagon Trail.

ADJOURNMENT

There being no further business, the meeting was considered adjourned at 6:50 p.m.

David B. Martin, Chair

Attest:

Ryan P. Herbert, Clerk-Treasurer

ORDINANCE NO. 1771-2025

**ADDITIONAL APPROPRIATION ORDINANCE FOR THE
CITY OF ANGOLA, INDIANA LOCAL ROAD AND BRIDGE MATCHING
GRANT FUND**

WHEREAS, it has been determined that it is now necessary to appropriate more money than was appropriated in the annual budget, now, therefore:

Section 1. Be it ORDAINED by the Common Council of the City of Angola, Steuben County, Indiana, that for the expenses of the taxing unit the following additional sums of money are hereby appropriated out of the funds named for the purpose specified, subject to the laws governing the same:

Fund Name:	<u>Amount Requested</u>	<u>Amount Approved</u>
Local Road and Bridge Matching Grant Fund Capital Outlays	<u>\$100,000</u>	_____
Total	<u>\$100,000</u>	

Section 2. This Ordinance shall be in full force and effect from and after its passage by the Common Council, approval of the Mayor, and approval of the Department of Local Government Finance, if applicable.

PASSED AND ADOPTED by the Common Council of the City of Angola, Indiana, on the _____ day of March 2025 by the vote of _____ ayes and _____ nays.

David B. Martin, Mayor
Presiding Officer

Attest:

Ryan P. Herbert, Clerk-Treasurer

This ordinance presented by me, the Clerk-Treasurer of the City of Angola, Indiana to the Mayor at the hour of _____ a.m./p.m. this _____ day of March 2025.

Ryan P. Herbert, Clerk-Treasurer

ORDINANCE NO. 1771-2025

This ordinance signed and approved by me, the Mayor of the City of Angola, Indiana this _____ day of March 2025.

David B. Martin, Mayor



CHANGE ORDER

Name of Project Angola WWTP Biosolids Improvements Project Number 661.7695.001 Page 1 of 3

Contractor Wagler & Associates, Inc. Change Order No. 2

Address 1211 Wohler Street, Angola, IN 46703 Date 2/20/2023

Description of Change		
Item 1	Add Landscaping Stone Along South Wall	\$ 1,577.98
Item 2	Extension of Existing Concrete Wall, SE Corner	\$ 3,999.00
Item 3		\$
Item 4		\$
Item 5		\$
Item 6		\$
Item 7		\$
Item 8		\$
Item 9		\$
Item 10		\$

Bid Amount \$ 635,627.21 Total Increase \$ 5,576.98
 Net Change through Change Order \$ 5,576.98
 Present Contract Amount \$ 641,204.19

Change in Time of Completion None to _____
 All claims against OWNER, which are incidental to or a consequence of this Change Order, are satisfied.

Prepared By: Jones & Henry Engineers, Ltd. By JH Williams Date 2/20/25

Accepted Wagler & Associates, Inc. By _____ Date _____
 Contractor

Approved City of Angola, Indiana By _____ Date _____
 Owner

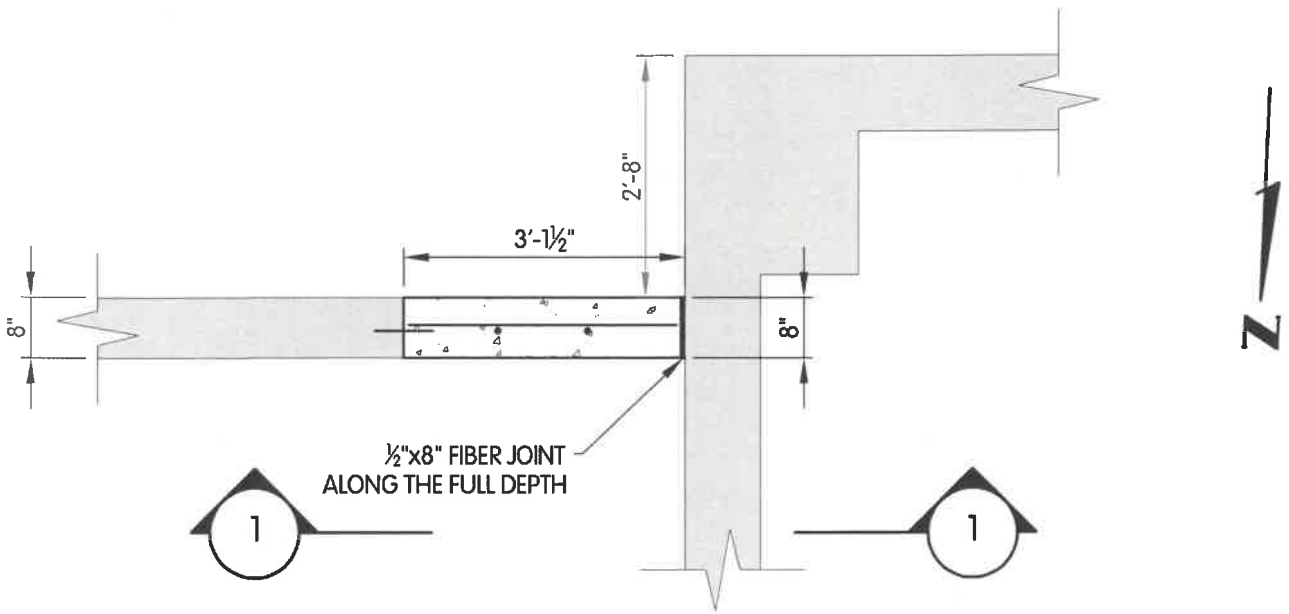

PLAN VIEW

1/2" = 1'-0"

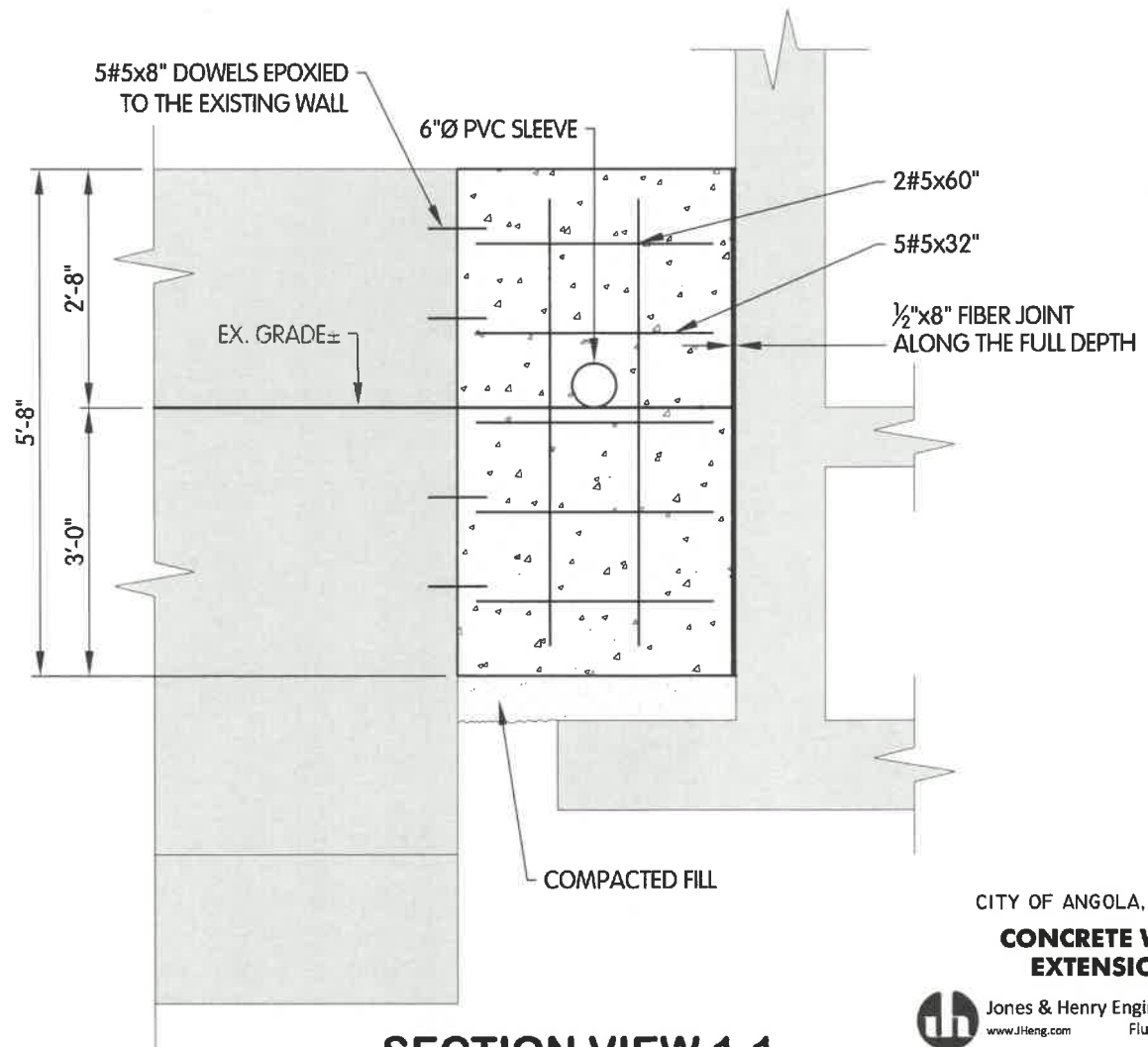

SECTION VIEW 1-1

CITY OF ANGOLA, INDIANA

CONCRETE WALL EXTENSION



Jones & Henry Engineers, Ltd.
www.JHeng.com Fluid thinking®

769500CONC.DWG

Change Order

Date:	Proposal Submitted To:	
2/4/2025	City of Angola Waste Water	
Phone #:	Street Address:	
260-665-6806	270 Redding Road	
Email:	City, State, Zip	Job #:
jgaff@angolain.org	Angola, IN 46703	24401D

We hereby submit specifications and estimates for:

SE Wall Extension

- *Includes excavation down to new building footer height
- *Includes installation of rebar and fiber expansion joint per drawing
- *Includes forming wall extension
- *Includes pouring 4500 psi concrete
- *Includes backfilling wall

Note: Work to be done during normal business hours.

Total Credit: \$ 3,999.00

All work is to be completed in a substantial and workman like manner for the bid price indicated. Contractor agrees to carry Workman's Compensation, Public Liability and Builder's Risk Insurance, to furnish customer with Certificate of Insurance prior to starting any work, and to pay all applicable Federal and State taxes. (A formal Construction Contract, No-Lien Agreement and Project Specifications will be prepared if applicable.)

Payments To Be Made As Outlined Below:

*The total bid price is valid for 30 days from proposal date

Authorizing Signature: Logan Casselman

Title: Estimator Date: 2/4/2025

Acceptance of Change Order ~ Wagler is hereby authorized to furnish all materials required as set forth in the above Change Order, for which the undersigned agrees to pay the amounts specified, and according to the terms thereof.

	Property Owner
	Property Owner
AWA # 7	Date of Acceptance

To accept this Change Order, please sign and date and return one (1) complete copy of this Change Order to our office.

Change Order		
Date:	Proposal Submitted To:	
1/30/2025	City of Angola Waste Water	
Phone #:	Street Address:	
260-665-6806	270 Redding Road	
Email:	City, State, Zip	Job #:
lgaff@angolain.org	Angola, IN 46703	24401D
We hereby submit specifications and estimates for:		
<p>Landscaping Stone Along South Wall</p> <p>*Includes placing #2 gravel landscaping stone along South wall for better maintenance</p>		
Note: Work to be done during normal business hours.		
Total Credit: \$		1,577.98
<p>All work is to be completed in a substantial and workman like manner for the bid price indicated. Contractor agrees to carry Workman's Compensation, Public Liability and Builder's Risk Insurance, to furnish customer with Certificate of Insurance prior to starting any work, and to pay all applicable Federal and State taxes. (A formal Construction Contract, No-Lien Agreement and Project Specifications will be prepared if applicable.)</p>		
		<p>Payments To Be Made As Outlined Below:</p> <hr/> <hr/> <hr/> <hr/>
<p>Authorizing Signature: <u>Logan Casselman</u></p>		<p>*The total bid price is valid for 30 days from proposal date</p>
Title:	Estimator	Date: 1/30/2025
<p>Acceptance of Change Order ~ Wagler is hereby authorized to furnish all materials required as set forth in the above Change Order, for which the undersigned agrees to pay the amounts specified, and according to the terms thereof.</p>		<p>Property Owner</p> <hr/> <p>Property Owner</p> <hr/> <p>Date of Acceptance</p>
AWA # 5		

To accept this Change Order, please sign and date and return one (1) complete copy of this Change Order to our office.